

4

3

2

1

THIS DRAWING IS UNPUBLISHED.

RELEASED FOR PUBLICATION

DEC 2019

© COPYRIGHT 2021

BY TE CONNECTIVITY

ALL RIGHTS RESERVED.

REVISIONS

P	LTR	DESCRIPTION	DATE	DWN	APVD
	A	RELEASE PER ECR-19-018164	19DEC2019	DFS	DFS
	A1	RELEASE PER PCN-21-101807	09APR2021	VNB	NS
	A2	RELEASE PER ECN-26-361787	02JAN2026	RT	DK

SECTION A-A

NOTES:

(A1) 1. MATERIAL:
 HEADER HOUSING: NYLON GF30%
 COLOR: BLACK
 TERMINALS: 1A: COPPER ALLOY
 MATING END PLATING: GOLD OVER NICKEL
 SOLDER TAIL END PLATING: TIN OVER NICKEL
 1B: COPPER ALLOY
 MATING END PLATING: TIN OVER NICKEL
 SOLDER TAIL END PLATING: TIN OVER NICKEL
 DISPENSED SEALANT: SILICONE
 FLANGE SEAL: SILICONE RUBBER
 COLOR: YELLOW

2. REFERENCE TE DRAWING 2295114 FOR CONNECTOR INTERFACE DIMENSIONS.

3. OPERATING TEMPERATURE; -40 TO +125°C

4. THIS PART MATES WITH 2-WAY PLUG, P/N 2292906-1. SEE SHEET 2 FOR KEYING ARRANGMENTS.

5. 2325102-1 AND 2325102-2 MUST USE MOUNTING CLIP P/N 2325098-X (SOLD SEPERATELY) FOR PROPER SEALING AND RETENTION WHEN ASSEMBLED TO A PANEL.

6. NOTE DELETED

7. NOTE DELETED

8. NOT RELEASED FOR PRODUCTION.

ISOMETRIC VIEWS SHOWN FOR REFERENCE ONLY

THIS DRAWING IS A CONTROLLED DOCUMENT.		DWN 28MAR2018 RAGHAV SATISH		
		CHK 28MAR2018 D.F. STACK		
DIMENSIONS: mm		APVD 23DEC2019 D. KLEIN	NAME 2POS ETHERNET HDR, 180 DEG, SLDR enetSEAL+	
TOLERANCES UNLESS OTHERWISE SPECIFIED:		PRODUCT SPEC 108-151045	APPLICATION SPEC 114-151045	
0 PLC ±- 1 PLC ±- 2 PLC ±- 3 PLC ±- 4 PLC ±- ANGLES ±- FINISH -		WEIGHT -	SIZE A3	CAGE CODE -
MATERIAL SEE NOTE 1		CUSTOMER DRAWING	DRAWING NO C-2325102	RESTRICTED TO -
		SCALE 2:1	SHEET 1 OF 9	REV A2

1470-19 (3/13)

Downloaded from Arrow.com

REVISIONS

P	LTR	DESCRIPTION	DATE	DWN	APVD
-	-	SEE SHEET 1	-	-	-

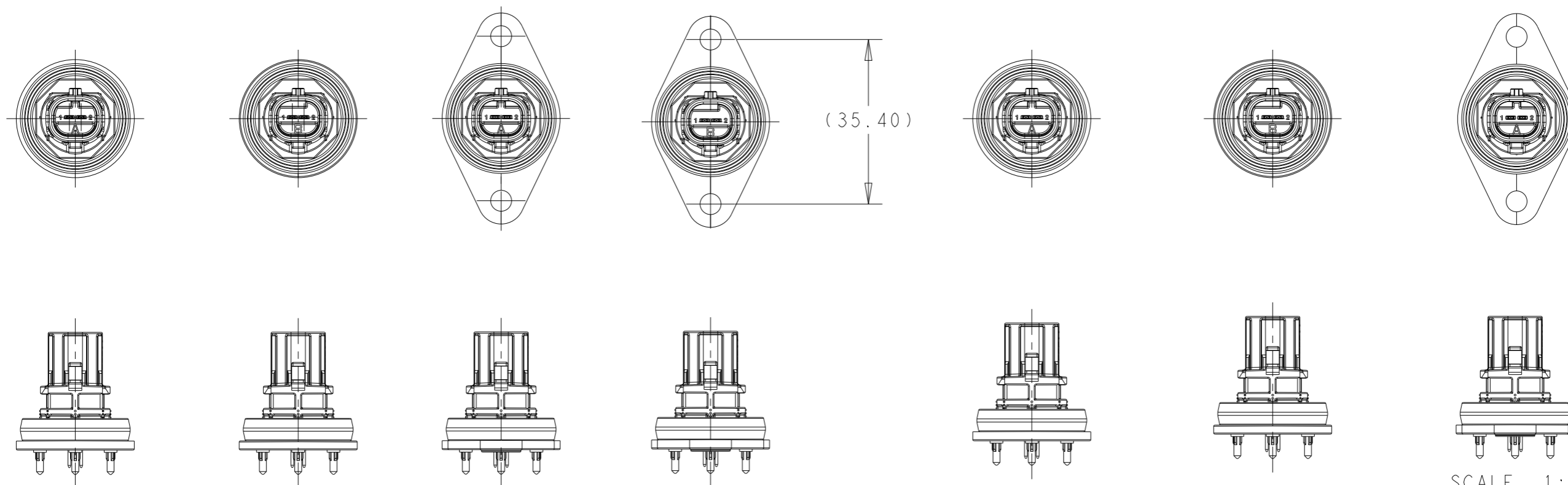

SCALE 1:1

2325102-1
AS SHOWN
KEY CODE A



2325102-2
AS SHOWN
KEY CODE B



2325102-7
AS SHOWN
KEY CODE A



2325102-8
AS SHOWN
KEY CODE B



2-2325102-1
AS SHOWN
KEY CODE A



2-2325102-2
AS SHOWN
KEY CODE B



2-2325102-7
AS SHOWN
KEY CODE A

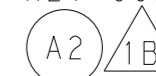

THIS DRAWING IS A CONTROLLED DOCUMENT.

DIMENSIONS:
mm

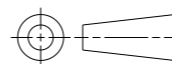

MATERIAL
SEE NOTE 1

TOLERANCES UNLESS
OTHERWISE SPECIFIED:

- 0 PLC ±-
- 1 PLC ±-
- 2 PLC ±-
- 3 PLC ±-
- 4 PLC ±-
- ANGLES ±-
- FINISH -

DWN 28MAR2018

RAGHAV SATISH

CHK 28MAR2018

D.F. STACK

APVD 23DEC2019

D. KLEIN

PRODUCT SPEC

108-151045

APPLICATION SPEC

114-151045

WEIGHT -

CUSTOMER DRAWING



TE Connectivity

NAME
2POS ETHERNET HDR, 180 DEG, SLDR
enetSEAL+

SIZE CAGE CODE DRAWING NO RESTRICTED TO

A3 - C-2325102 -

SCALE 2:1 SHEET 2 OF 9 REV A2

REVISIONS					
P	LTR	DESCRIPTION	DATE	DWN	APVD
	-	SEE SHEET 1	-	-	-

ADDITIONAL NOTES REGARDING PANEL AND PCB FITMENT:

- 10. RECOMMENDED KEEP OUT REGION TO ENSURE PROPER ASSEMBLY TO PANEL/ENCLOSURE.
- 11. RECOMMENDED KEEP OUT REGION TO ENSURE PROPER CLIP ASSEMBLY.
- 12. SURFACE FINISH REQUIREMENT APPLIES WITHIN KEEPOUT REGION.
- 13. THICKNESS BETWEEN KEEP OUT REGIONS MUST MEET THICKNESS REQUIREMENT FOR SPECIFIC MOUNTING CLIP TO BE USED PER TE CUSTOMER DRAWING 2325098.
- 14. HOLES ONLY NECESSARY FOR 2325102-7/8 VARIANTS.
- 15. SEALING SURFACE, NO BURRS, SCRATCHES OR TOOL MARKS ALLOWED.
- 16. REMOVE SHARP EDGES. R0.5MM MAX.
- 17. X BASIC AND Y BASIC TO BE DEFINED BY THE CUSTOMER.
- 18. RECOMMENDED KEEP OUT REGION TO ENSURE PROPER ASSEMBLY WITH MATING PLUG. THE GEOMETRY SHOWN FOR THE KEEP OUT REGION IS ONLY NECESSARY IF THE DISTANCE FROM THE OUTSIDE SURFACE OF THE ENCLOSURE TO THE HEADER BOTTOMING SURFACE/SURFACES EXCEEDS 11.5MM.

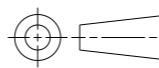
THIS DRAWING IS A CONTROLLED DOCUMENT.		DWN 28MAR2018 RAGHAV SATISH	 TE Connectivity		
DIMENSIONS: mm		CHK 28MAR2018 D.F. STACK			
TOLERANCES UNLESS OTHERWISE SPECIFIED:		APVD 23DEC2019 D. KLEIN	NAME 2POS ETHERNET HDR, 180 DEG, SLDR enetSEAL+		
		PRODUCT SPEC 108-151045	RESTRICTED TO		
MATERIAL SEE NOTE 1		APPLICATION SPEC 114-151045	SIZE A3	CAGE CODE -	DRAWING NO C-2325102
		WEIGHT -	SCALE 1:1 SHEET 3 OF 9 REV A2		
		CUSTOMER DRAWING			

REVISIONS

P	LTR	DESCRIPTION	DATE	DWN	APVD
	-	SEE SHEET 1	-	-	-

RECOMMENDED ENCLOSURE GEOMETRY FOR ASSEMBLIES
2325102-1 AND 2325102-2

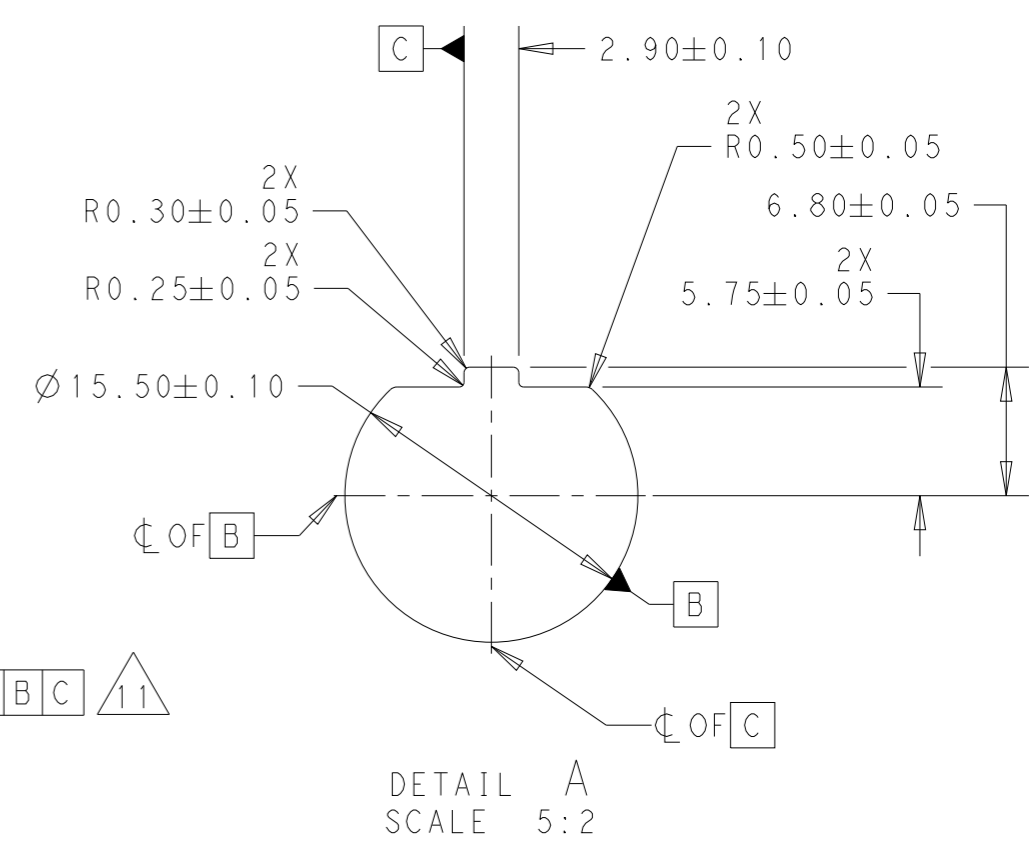
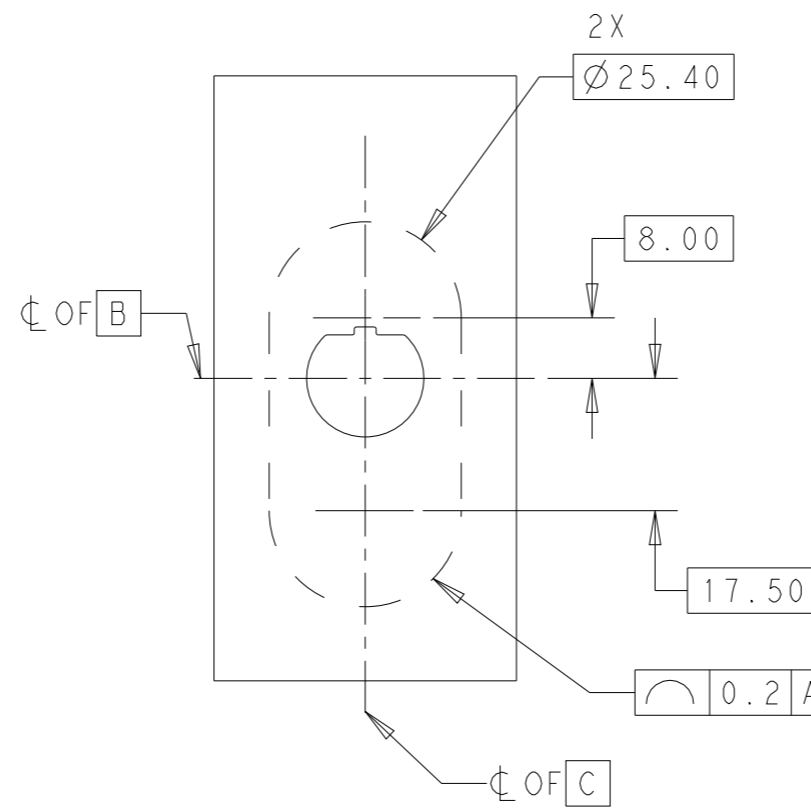
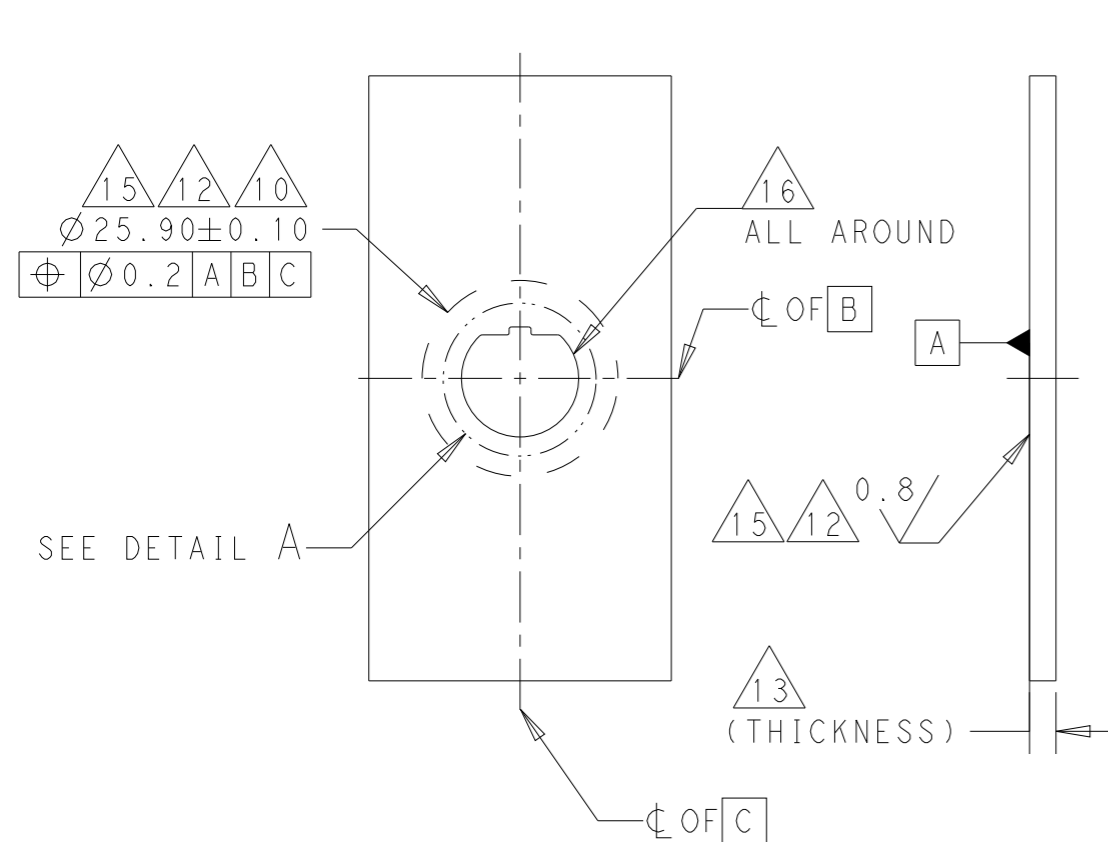

DETAIL A
SCALE 5:2

THIS DRAWING IS A CONTROLLED DOCUMENT.		DWN RAGHAV SATISH 28MAR2018	 TE Connectivity			
DIMENSIONS: mm		CHK D.F. STACK 28MAR2018				
TOLERANCES UNLESS OTHERWISE SPECIFIED:		APVD D. KLEIN 23DEC2019	NAME 2POS ETHERNET HDR, 180 DEG, SLDR enetSEAL+			
0 PLC \pm - 1 PLC \pm - 2 PLC \pm - 3 PLC \pm - 4 PLC \pm - ANGLES \pm - FINISH -		PRODUCT SPEC 108-151045	SIZE A3	CAGE CODE -	DRAWING NO C-2325102	RESTRICTED TO -
MATERIAL SEE NOTE 1		APPLICATION SPEC 114-151045	SCALE 1:1		SHEET 4 OF 9	REV A2
		WEIGHT -	CUSTOMER DRAWING			

REVISIONS

P	LTR	DESCRIPTION	DATE	DWN	APVD
	-	SEE SHEET 1	-	-	-

ALTERNATE RECOMMENDED ENCLOSURE GEOMETRY FOR ASSEMBLIES
2325102-1 AND 2325102-2

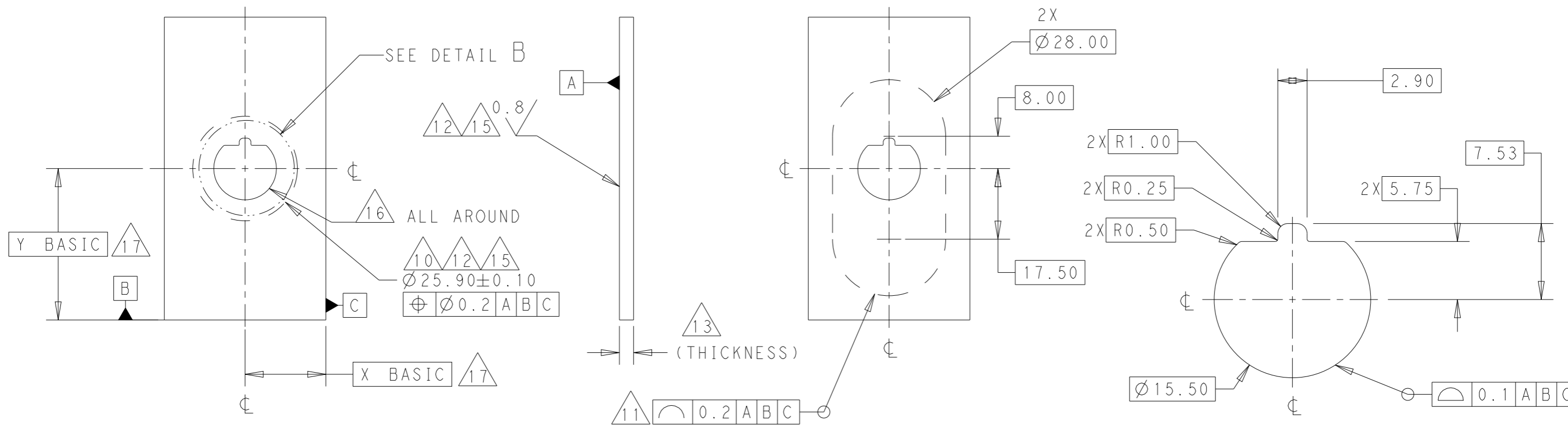

DETAIL B
SCALE 5:2

THIS DRAWING IS A CONTROLLED DOCUMENT.		DWN 28MAR2018 RAGHAV SATISH				
DIMENSIONS: mm		CHK 28MAR2018 D.F. STACK				
TOLERANCES UNLESS OTHERWISE SPECIFIED:		APVD 23DEC2019 D. KLEIN	NAME 2POS ETHERNET HDR, 180 DEG, SLDR enetSEAL+			
<ul style="list-style-type: none"> 0 PLC ±- 1 PLC ±- 2 PLC ±- 3 PLC ±- 4 PLC ±- ANGLES ±- FINISH - 		PRODUCT SPEC 108-151045	SIZE A3	CAGE CODE -	DRAWING NO C-2325102	RESTRICTED TO -
MATERIAL SEE NOTE 1		APPLICATION SPEC 114-151045	SCALE 1:1		SHEET 5 OF 9	REV A2
		WEIGHT -	CUSTOMER DRAWING			

REVISIONS

P	LTR	DESCRIPTION	DATE	DWN	APVD
-	-	SEE SHEET 1	-	-	-

RECOMMENDED ENCLOSURE GEOMETRY FOR ASSEMBLIES
2325102-7 AND 2325102-8

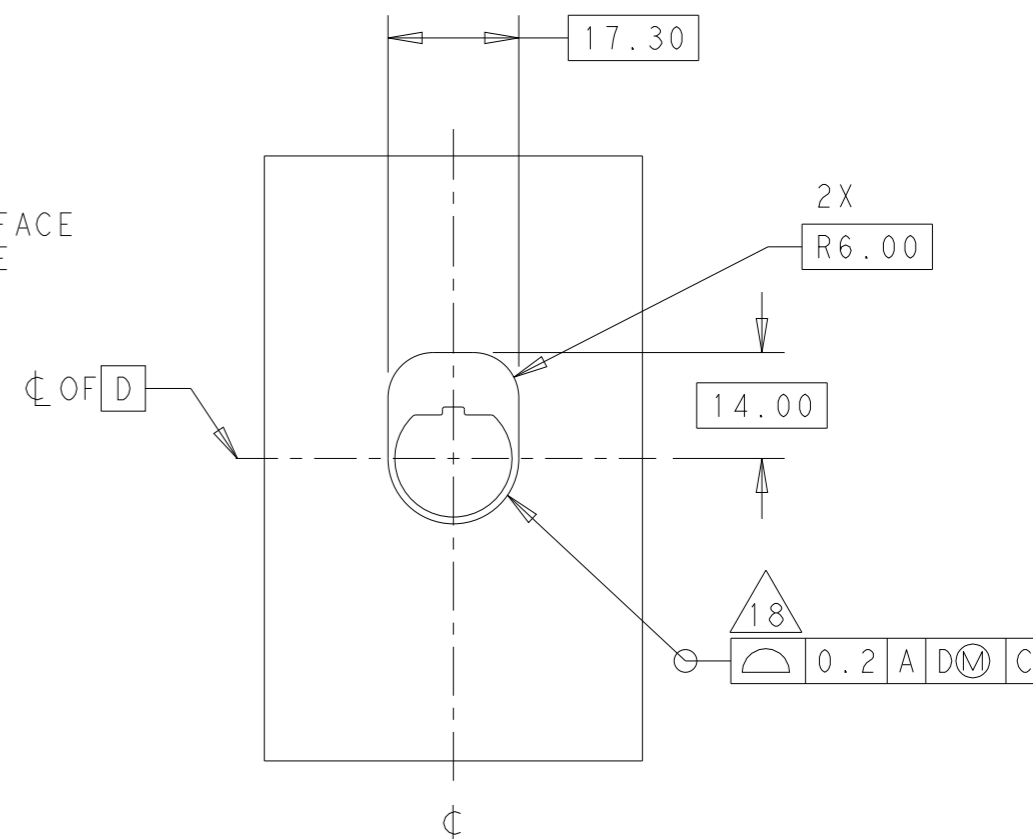
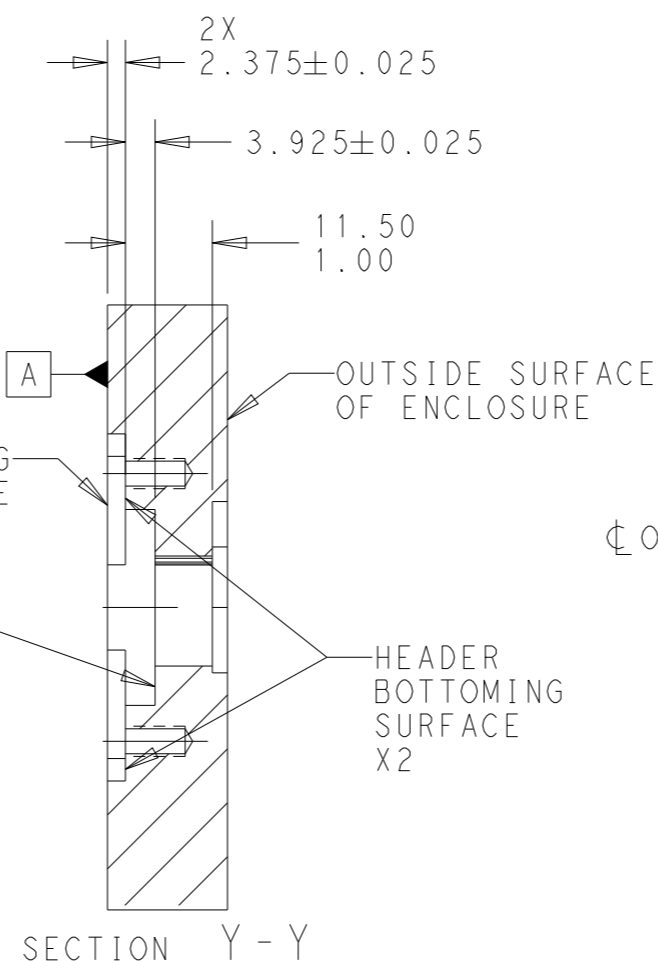
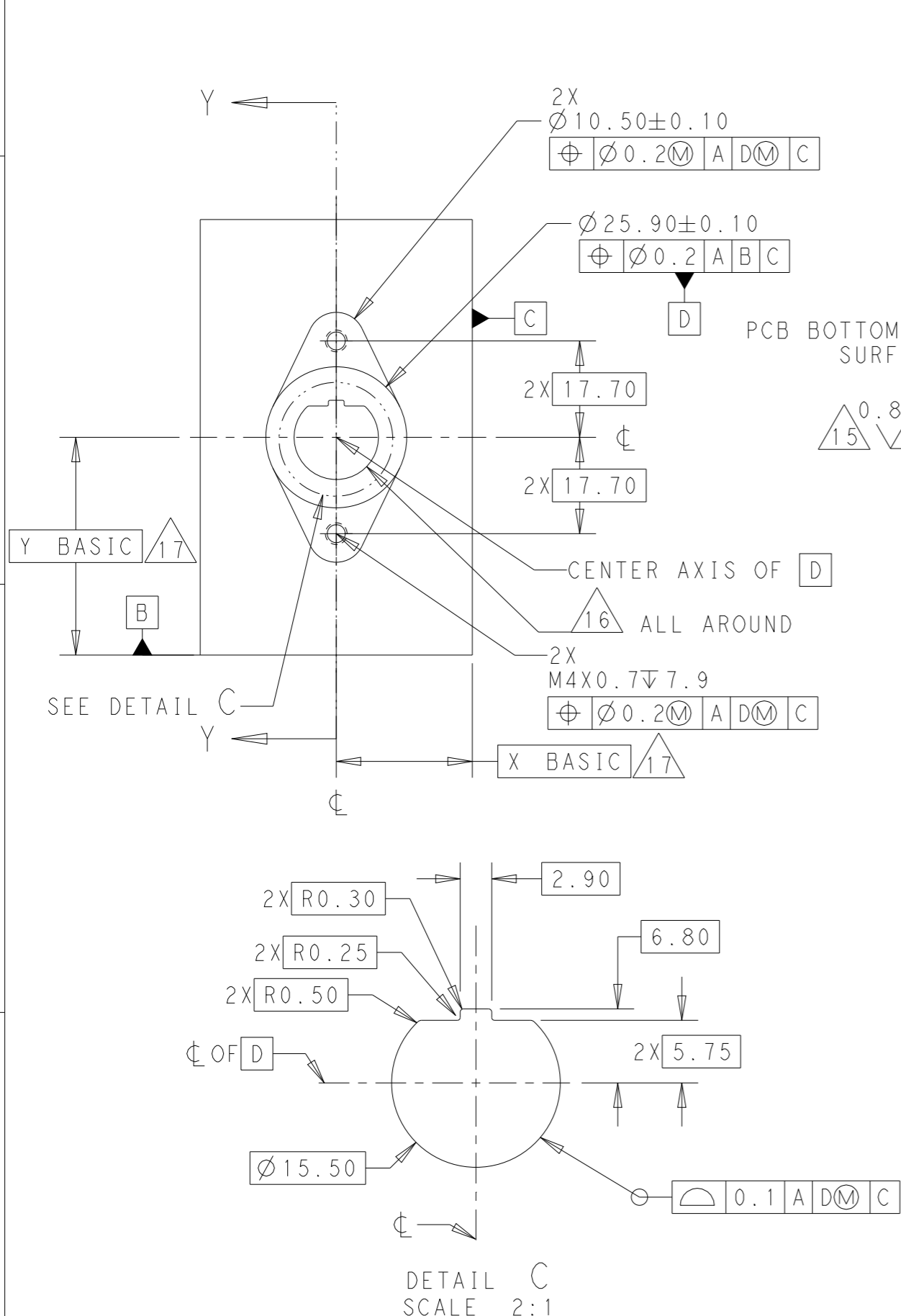

THIS DRAWING IS A CONTROLLED DOCUMENT.

DIMENSIONS:
mm

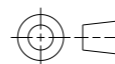

MATERIAL
SEE NOTE 1

TOLERANCES UNLESS OTHERWISE SPECIFIED:
0 PLC ±-
1 PLC ±-
2 PLC ±-
3 PLC ±-
4 PLC ±-
ANGLES ±-
FINISH -

DWN 28MAR2018
RAGHAV SATISH
CHK 28MAR2018
D.F. STACK
APVD 23DEC2019
D.KLEIN
PRODUCT SPEC
108-151045
APPLICATION SPEC
114-151045
WEIGHT -

STE TE Connectivity

NAME
2POS ETHERNET HDR, 180 DEG, SLDR enetSEAL+

SIZE A3	CAGE CODE -	DRAWING NO C-2325102	RESTRICTED TO -
------------	----------------	-------------------------	--------------------

CUSTOMER DRAWING SCALE 1:1 SHEET 6 OF 9 REV A2

REVISIONS					
P	LTR	DESCRIPTION	DATE	DWN	APVD
-	-	SEE SHEET 1	-	-	-

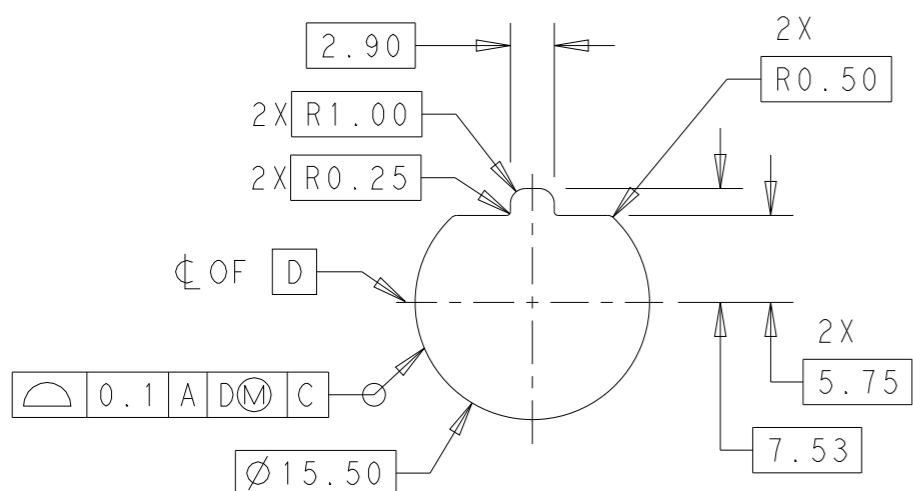
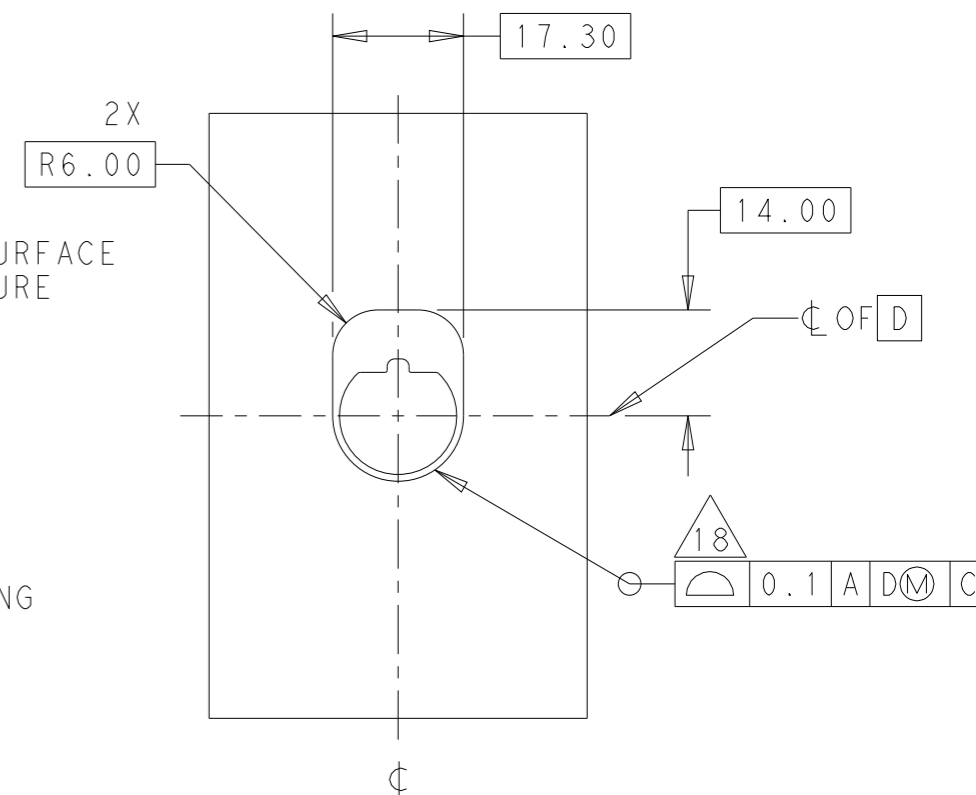
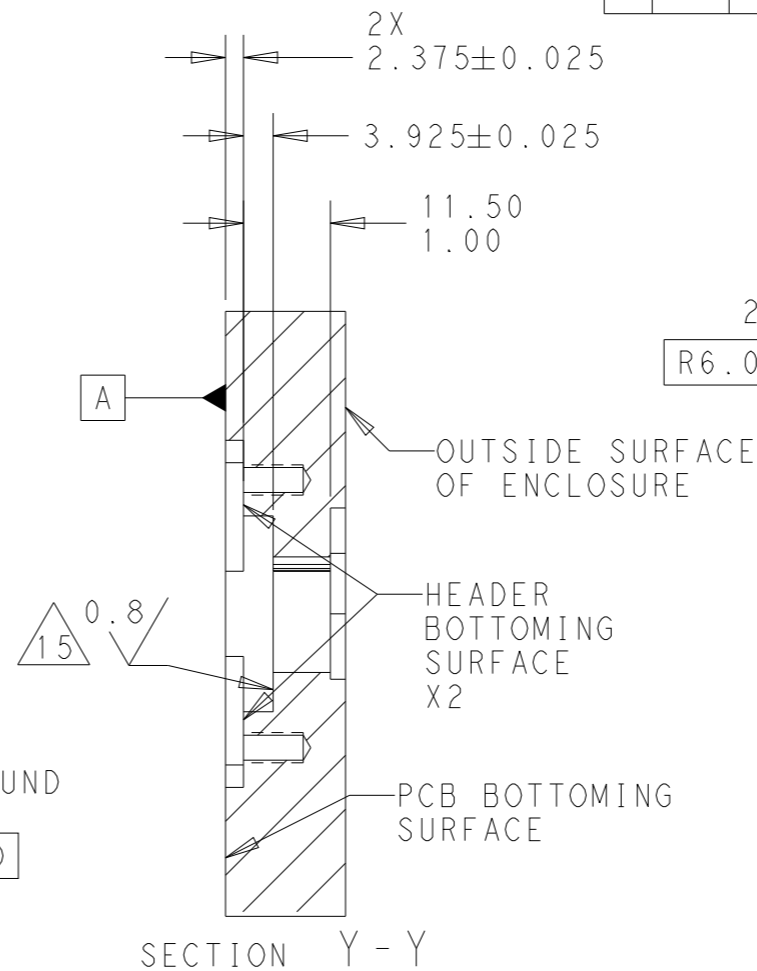
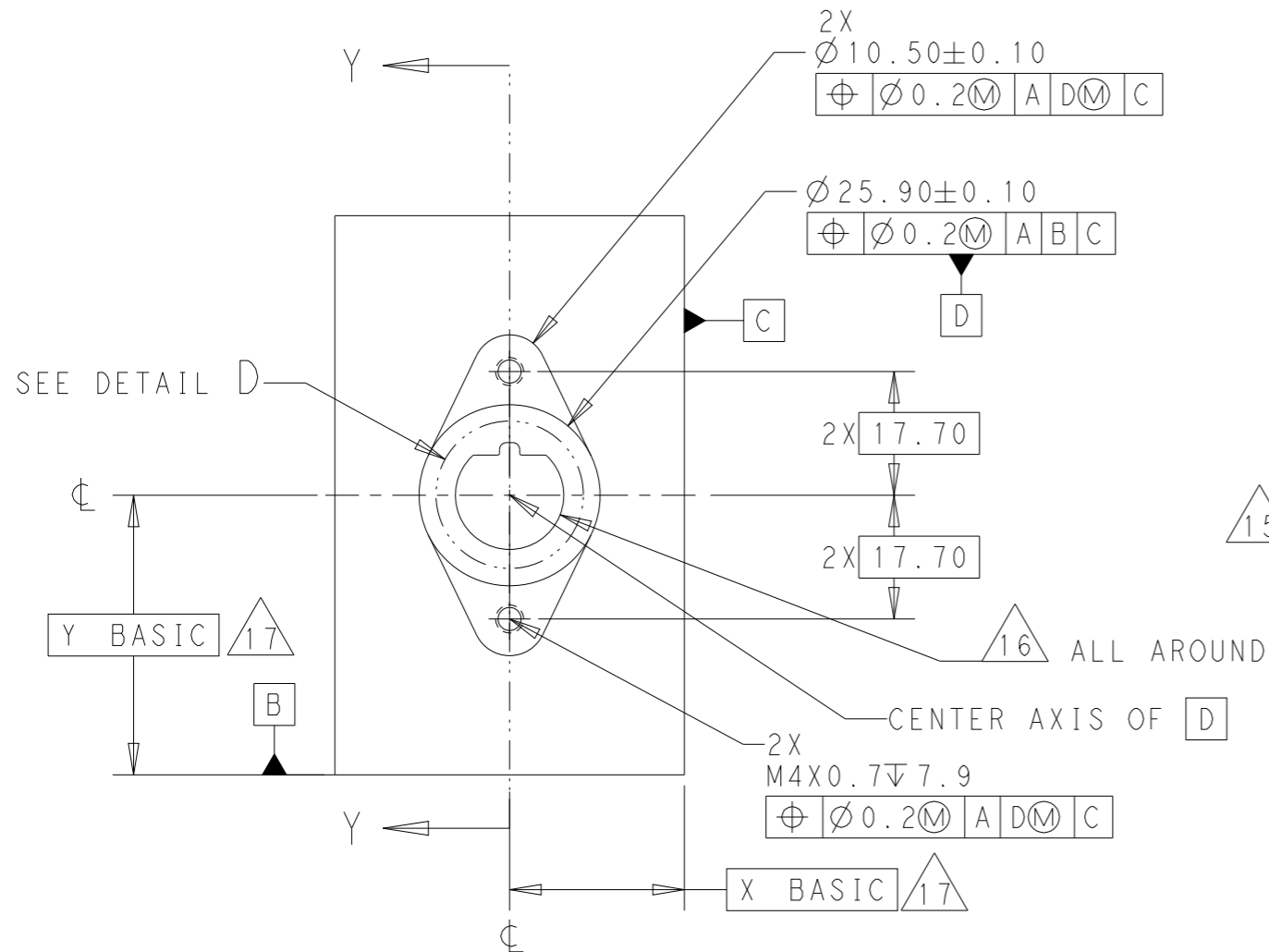

DETAIL D
SCALE 2:1

THIS DRAWING IS A CONTROLLED DOCUMENT.		DWN 28MAR2018 RAGHAV SATISH	TE Connectivity		
DIMENSIONS: mm		CHK 28MAR2018 D.F. STACK			
TOLERANCES UNLESS OTHERWISE SPECIFIED:		APVD 23DEC2019 D. KLEIN	NAME 2POS ETHERNET HDR, 180 DEG, SLDR enetSEAL+		
0 PLC ±-		PRODUCT SPEC 108-151045	APPLICATION SPEC 114-151045		
1 PLC ±-		WEIGHT -	SIZE A3	CAGE CODE -	DRAWING NO C-2325102
2 PLC ±-		CUSTOMER DRAWING	SCALE 1:1	SHEET 7 OF 9	REV A2
3 PLC ±-					
4 PLC ±-					
ANGLES ±-					
FINISH -					
MATERIAL SEE NOTE 1					

4

3

2

1

THIS DRAWING IS UNPUBLISHED.

RELEASED FOR PUBLICATION

DEC 2019

© COPYRIGHT 2021 BY TE CONNECTIVITY

ALL RIGHTS RESERVED.

REVISIONS

P	LTR	DESCRIPTION	DATE	DWN	APVD
-	-	SEE SHEET 1	-	-	-

SCALE 3:2

SCALE 3:2

SCALE 2:1
RECOMMENDED PCB LAYOUT

THIS DRAWING IS A CONTROLLED DOCUMENT.		DWN 28MAR2018 RAGHAV SATISH	 TE Connectivity	
DIMENSIONS: mm		CHK 28MAR2018 D.F. STACK		
TOLERANCES UNLESS OTHERWISE SPECIFIED:		APVD 23DEC2019 D. KLEIN	NAME 2POS ETHERNET HDR, 180 DEG, SLDR enetSEAL+	
0 PLC ±-		PRODUCT SPEC 108-151045	SIZE A3	
1 PLC ±-		APPLICATION SPEC 114-151045	CAGE CODE -	
2 PLC ±-		WEIGHT -	DRAWING NO C-2325102	
3 PLC ±-		CUSTOMER DRAWING	RESTRICTED TO -	
4 PLC ±-			SCALE 1:1 SHEET 8 OF 9 REV A2	
ANGLES ±-				
FINISH -				
MATERIAL SEE NOTE 1				

1470-19 (3/13)

Downloaded from Arrow.com

REVISIONS

P	LTR	DESCRIPTION	DATE	DWN	APVD
-	-	SEE SHEET 1	-	-	-

RECOMMENDED (OPTIONAL) STAKE GEOMETRY FOR SECURING HEADER TO PCB

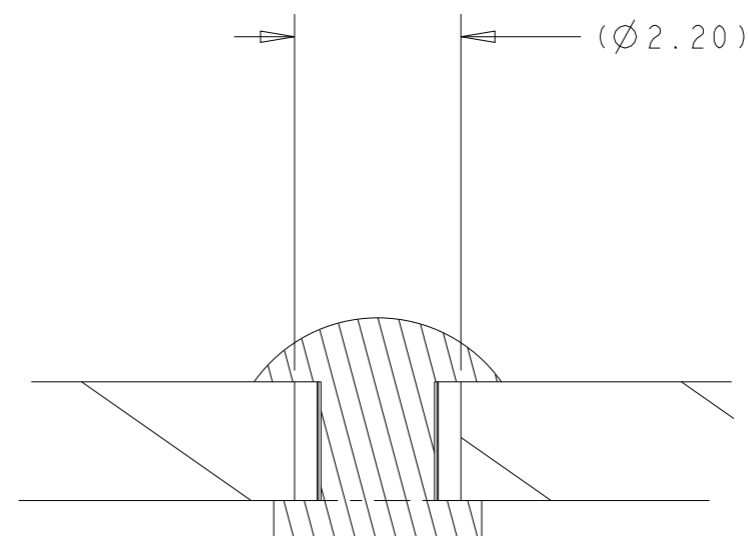
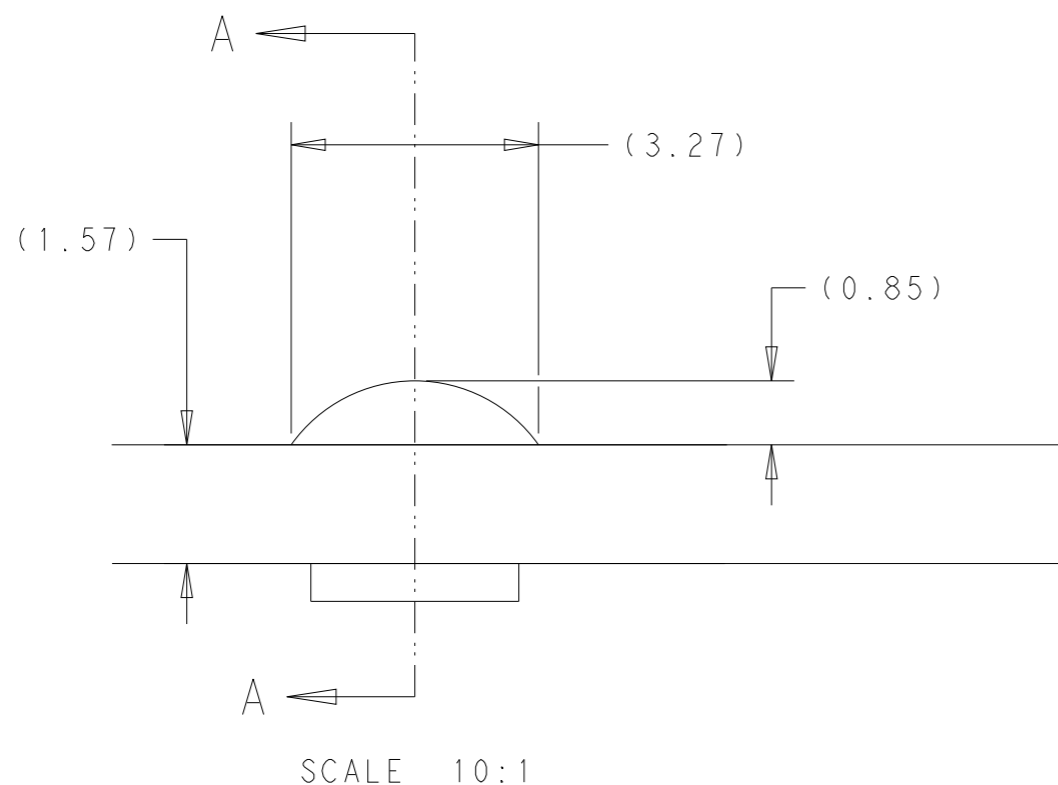

SECTION A - A

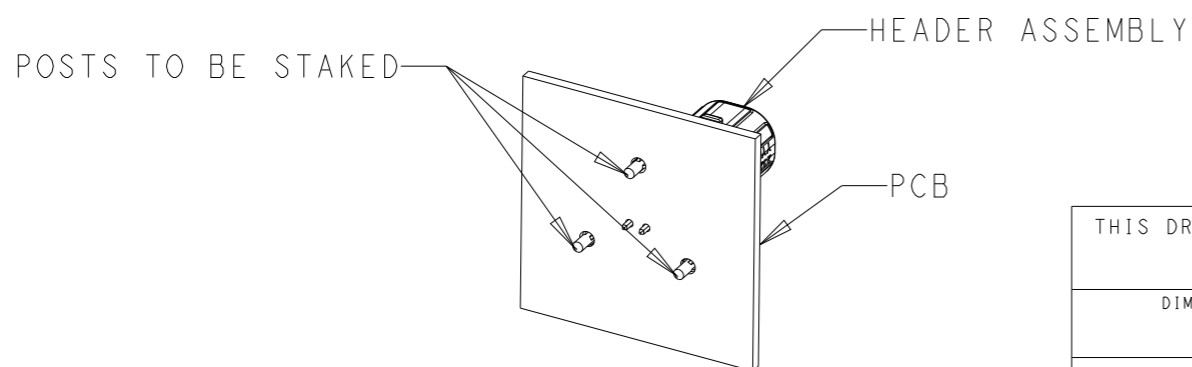

ISOMETRIC VIEW SHOWN FOR REFERENCE ONLY

THIS DRAWING IS A CONTROLLED DOCUMENT.		DWN RAGHAV SATISH 28MAR2018		
DIMENSIONS: mm		CHK D.F. STACK 28MAR2018		
TOLERANCES UNLESS OTHERWISE SPECIFIED:		APVD D. KLEIN 23DEC2019	NAME 2POS ETHERNET HDR, 180 DEG, SLDL enetSEAL+	
0 PLC ±-		PRODUCT SPEC 108-151045	SIZE A3	
1 PLC ±-		APPLICATION SPEC 114-151045	CAGE CODE -	DRAWING NO C-2325102
2 PLC ±-		WEIGHT -	RESTRICTED TO -	
3 PLC ±-		CUSTOMER DRAWING	SCALE 1:1	SHEET 9 OF 9
4 PLC ±-				REV A2
ANGLES ±-				
FINISH -				
MATERIAL SEE NOTE 1				