

NOTE:
ONLY SUITABLE FOR RT360 SERIES 1804 and 1802 LAYOUT
CONNECTOR

REVISIONS					
REV	ECO	DESCRIPTION	DATE	BY	APPR
A1	-	PRELIMINARY DESIGN	26/Jul/23	RONALD	TOMMY

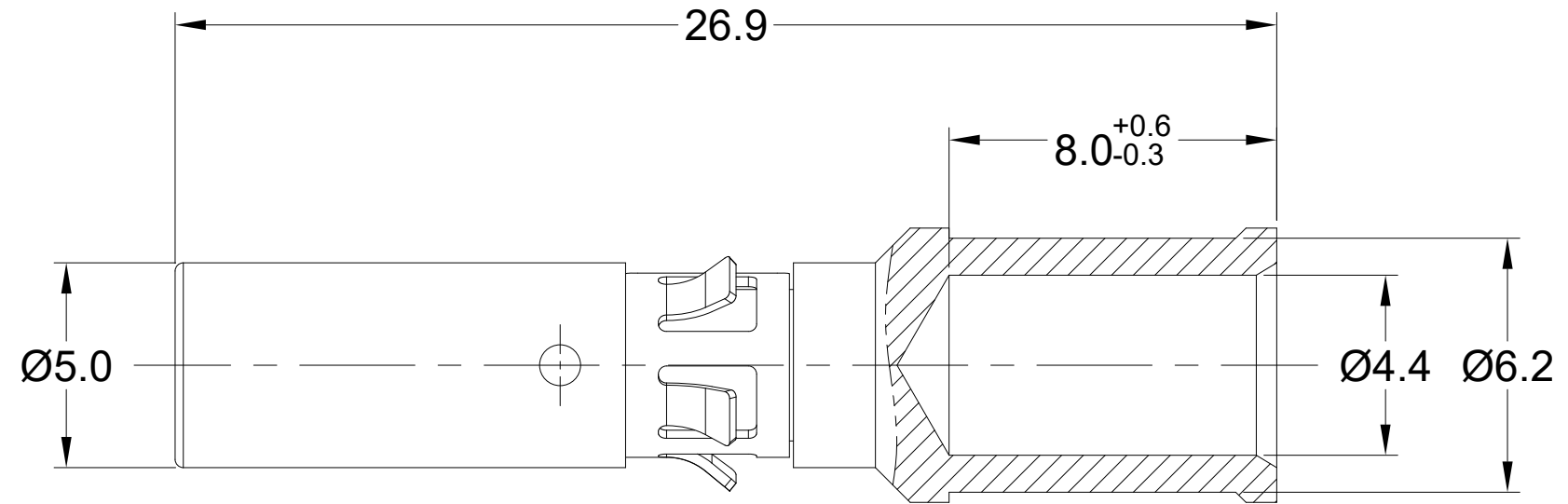
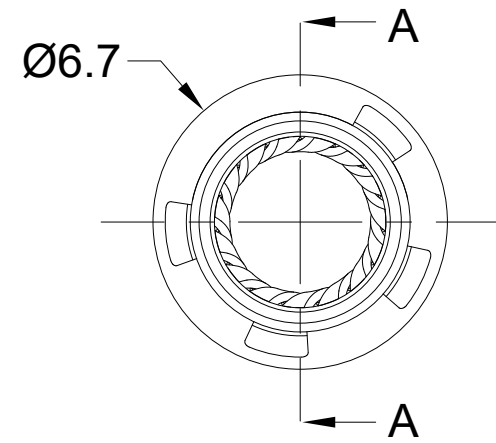

SECTION A-A

NOTES: (UNLESS OTHERWISE SPECIFIED)

- MATERIAL:
 - CONTACT BODY: COPPER ALLOY.
 - POSITIONING CLIP: COPPER ALLOY.
 - CROWN SPRING: COPPER ALLOY.
- SPECIFICATIONS:
 - CURRENT RATING: 56A(MAX).
 - TERMINATION TYPE: CRIMPING.
 - WIRE RANGE: 8 AWG.
- SUITABLE CONTACT : MP10A25x-8A.
- RoHS COMPLIANT.
- ALL DIMENSIONS ARE FOR REFERENCE USE ONLY.

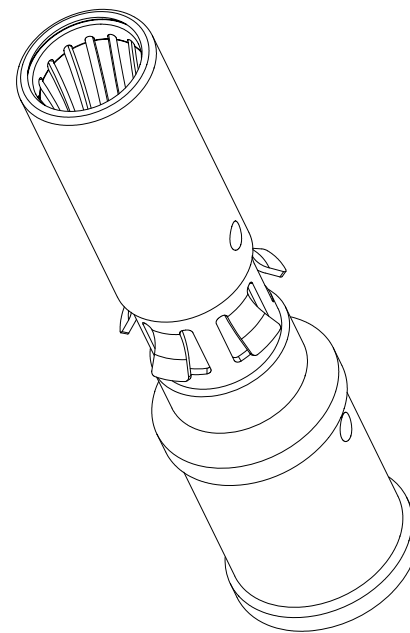

P/N	CONTACT PLATING(MATING AREA)
MS10A25F-8A	GOLD FLASH PLATING OVER NICKEL.
MS10A25S-8A	SILVER PLATING OVER NICKEL.

QUANTITY	SEE PART NUMBER CHART	PART NUMBER	DESCRIPTION	ITEM
MATERIALS LIST				
UNLESS OTHERWISE SPECIFIED		SIGNATURES		DATE
1) All dimensions are in metric(mm).		DRAWN: RONALD	26/Jul/23	
2) Tolerances are as follows:		CHECKED: JOE	27/Jul/23	
1 PL DEC ±0.30		ENGINEER:		
2 PL DEC ±0.15		APPROVAL: TOMMY	28/Jul/23	
3 PL DEC ±0.08		CUSTOMER:		
3) Note reference =		THIS DRAWING IS SUPPLIED FOR INFORMATION ONLY. DESIGN FEATURES, SPECIFICATIONS AND PERFORMANCE DATA SHOWN HEREON ARE THE PROPERTY OF THE AMPHENOL CORPORATION. NO RIGHTS OF REPRODUCTION ARE IMPLIED. ALL DIMENSIONS ARE SUBJECT TO NORMAL MANUFACTURING VARIATIONS.		
MATERIAL SPECIFICATIONS:		EcoMate RM, SOCKET CONTACT, Ø3.6mm, CRIMP 8 AWG		
PROCESS SPECIFICATIONS:		SIZE	TYPE	DWG NO.
NEXT ASSY:		B	C-	MS10A25x-8A
		SCALE: NONE		REVISION A1
		SHEET 1 OF 1		

TITLE: EcoMate RM, SOCKET CONTACT, Ø3.6mm, CRIMP 8 AWG
DWG NO: MS10A25x-8A
REV: A1
SH: 1
OF: 1