

# Data Sheet | Item Number: 769-608/006-000

1-conductor male connector; CAGE CLAMP®; 4 mm<sup>2</sup>; Pin spacing 5 mm; 8-pole; Snap-in flange; 4,00 mm<sup>2</sup>; gray

<https://www.wago.com/769-608/006-000>

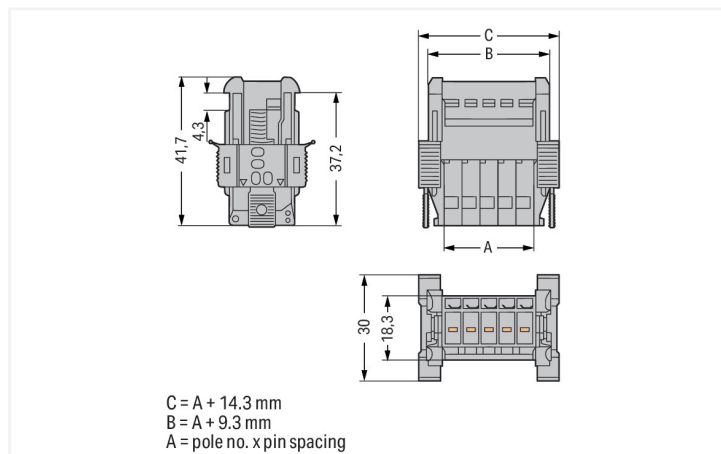
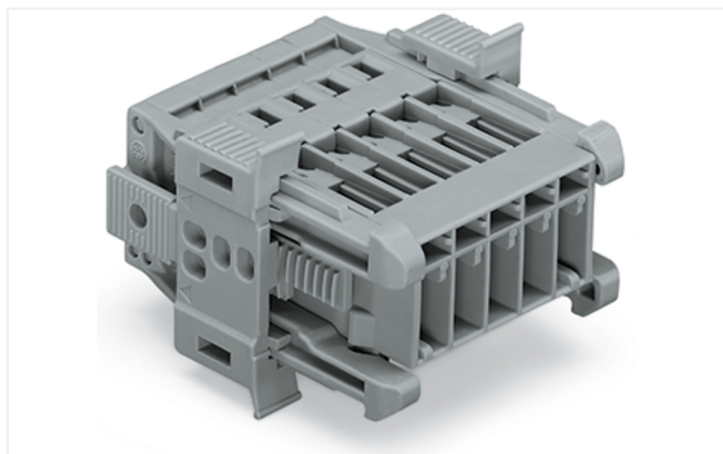

Color: ■ gray

Similar to illustration

Dimensions in mm

Male connector, 769 Series, CAGE CLAMP®

Fault-free electrical installations are guaranteed with this male connector (item number 769-608/006-000). Ensure that the strip lengths are between 8 and 9 mm when connecting conductors to this male connector. Pluggable rail-mount terminal blocks are mainly used in switchgear units and control systems (e.g., in railroad technology). They are essentially a combination of rail-mount terminal blocks and pluggable connectors. You can also pre-assemble installations thanks to the variable wiring system. This saves both time and money during manufacture, installation, operation, and maintenance. This product features conductor terminals and utilizes CAGE CLAMP®. Our CAGE CLAMP® connection offers a convenient and maintenance-free way to connect all types of conductors. You do not need to prepare the conductor in any way, such as crimping ferrules. Dimensions: (54.3 x 30 x 41.7) mm (width x height x depth). Depending on the type of conductor, this male connector is ideal for conductor cross sections ranging from 0.08 mm<sup>2</sup> to 4 mm<sup>2</sup>.

An operating tool is used to operate this male connector/plug.

## Electrical data

### Ratings per IEC/EN

Nominal voltage (III/3)	500 V
Rated impulse withstand voltage (III / 3)	6 kV
Rated current	32 A
Legend (ratings)	(III / 3) ≙ Overvoltage category III / Pollution degree 3

### General information

Wiring direction	Side-entry wiring
------------------	-------------------

## Connection Data

Clamping units	8
Total number of potentials	8

### Connection 1

Connection technology	CAGE CLAMP®
Actuation type	Operating tool
Connectable conductor materials	Copper
Nominal cross-section	4 mm <sup>2</sup> / 12 AWG
Solid conductor	0.08 ... 4 mm <sup>2</sup> / 28 ... 12 AWG
Fine-stranded conductor	0.08 ... 4 mm <sup>2</sup> / 28 ... 12 AWG
Strip length	8 ... 9 mm / 0.31 ... 0.35 inches

### Connection 1

Pole number	8
Wiring direction	Side-entry wiring

### Physical data

Pin spacing	5 mm / 0.197 inches
Width	54.3 mm / 2.138 inches
Height	30 mm / 1.181 inches
Depth	41.7 mm / 1.642 inches

### Mechanical data

Variable coding	Yes
Direct ground contact to DIN-rail/drilled hole/housing	No
Mounting type	Snap-in flange variant
Anti-rotation protection	Yes
Suitable for through-panel applications	Yes

### Plug-in connection

Contact type (pluggable connector)	Male connector/plug
Connector (connection type)	for conductor
Mismating protection	No

### Material data

Note (material data)	<a href="#">Information on material specifications can be found here</a>
Color	gray
Material group	I
Insulation material (main housing)	Polyamide (PA66)
Flammability class per UL94	V0
Fire load	0.543 MJ
Weight	27.9 g

### Environmental requirements

Processing temperature	-35 ... +85 °C
Continuous operating temperature	-60 ... +105 °C

### Commercial data

Product Group	18 (X-COM-System)
PU (SPU)	25 pcs
Packaging type	Box
Country of origin	PL
GTIN	4045454917050
Customs tariff number	85366930000

**Product Classification**

UNSPSC	39121409
eCl@ss 10.0	27-14-11-06
eCl@ss 9.0	27-14-11-06
ETIM 9.0	EC001284
ETIM 10.0	EC001284
ECCN	NO US CLASSIFICATION

**Environmental Product Compliance**

RoHS Compliance Status	Compliant, No Exemption
------------------------	-------------------------

**Approvals / Certificates**

**General approvals**



Approval	Standard	Certificate Name
CCA DEKRA Certification B.V.	EN 61984	2190419.02
CCA DEKRA Certification B.V.	IEC 61984	NL-47799/A1
CSA CSA Group	C22.2	1101144
UL Underwriters Laboratories Inc.	UL 1059	E45172
UL Underwriters Laboratories Inc.	UL 1977	20151210-E45171

**Declarations of conformity and manufacturer's declarations**



Approval	Standard	Certificate Name
Railway WAGO GmbH & Co. KG	-	Z00004428.000

**Downloads**

**Environmental Product Compliance**

Compliance Search
Environmental Product Compliance 769-608/006-000



**Documentation**

Bid Text			
769-608/006-000	19.02.2019	xml 3.14 KB	
769-608/006-000	04.10.2017	doc 25.00 KB	

CAD/CAE-Data

**CAD data**  
 2D/3D Models  
 769-608/006-000

**CAE data**  
 EPLAN Data Portal  
 769-608/006-000   
 WSCAD Universe  
 769-608/006-000   
 ZUKEN Portal  
 769-608/006-000

1 Compatible Products

1.1 System counterpart

1.1.1 Female connector/socket



**Item No.: 769-108**  
 1-conductor female connector; CAGE CLAMP®; 4 mm<sup>2</sup>; Pin spacing 5 mm; 8-pole; coding finger; 4,00 mm<sup>2</sup>; gray

**Item No.: 769-108/021-000**  
 1-conductor female connector; CAGE CLAMP®; 4 mm<sup>2</sup>; Pin spacing 5 mm; 8-pole; coding finger; Lateral locking levers; 4,00 mm<sup>2</sup>; gray

**Item No.: 769-128**  
 2-conductor female connector; CAGE CLAMP®; 4 mm<sup>2</sup>; Pin spacing 5 mm; 8-pole; coding finger; 4,00 mm<sup>2</sup>; gray

1.2 Optional Accessories

1.2.1 Coding

1.2.1.1 Coding



**Item No.: 769-435**  
 Coding pin; for coding of female plugs; for carrier terminal blocks / male connectors; orange

1.2.2 Ferrule

1.2.2.1 Ferrule



**Item No.: 216-201**  
 Ferrule; Sleeve for 0.5 mm<sup>2</sup> / 20 AWG; insulated; electro-tin plated; electrolytic copper; acc. to DIN 46228, Part 4/09.90; white



**Item No.: 216-101**  
 Ferrule; Sleeve for 0.5 mm<sup>2</sup> / AWG 22; un-insulated; electro-tin plated; silver-colored



**Item No.: 216-202**  
 Ferrule; Sleeve for 0.75 mm<sup>2</sup> / 18 AWG; insulated; electro-tin plated; gray



**Item No.: 216-102**  
 Ferrule; Sleeve for 0.75 mm<sup>2</sup> / 18 AWG; un-insulated; electro-tin plated; silver-colored



**Item No.: 216-203**  
 Ferrule; Sleeve for 1 mm<sup>2</sup> / AWG 18; insulated; electro-tin plated; red



**Item No.: 216-103**  
 Ferrule; Sleeve for 1 mm<sup>2</sup> / AWG 18; un-insulated; electro-tin plated



**Item No.: 216-204**  
 Ferrule; Sleeve for 1.5 mm<sup>2</sup> / AWG 16; insulated; electro-tin plated; black



**Item No.: 216-104**  
 Ferrule; Sleeve for 1.5 mm<sup>2</sup> / AWG 16; un-insulated; electro-tin plated; silver-colored



**Item No.: 216-206**  
 Ferrule; Sleeve for 2.5 mm<sup>2</sup> / AWG 14; insulated; electro-tin plated; blue

### 1.2.3 Insulation stop

#### 1.2.3.1 Insulation stop



**Item No.: 769-470**  
Insulation stop; 0.08 - 0.2 mm<sup>2</sup> "s" (0.14 mm<sup>2</sup> "f-st"); 5 pieces/strip; white



**Item No.: 769-471**  
Insulation stop; 0.25 - 0.5 mm<sup>2</sup>; 5 pieces/strip; light gray



**Item No.: 769-472**  
Insulation stop; 0.75 - 1 mm<sup>2</sup>; 5 pieces/strip; dark gray

### 1.2.4 Marking

#### 1.2.4.1 Marker



**Item No.: 248-501**  
Mini-WSB marking card; as card; not stretchable; plain; snap-on type; white

#### 1.2.4.2 Marking strip



**Item No.: 210-833**  
Marking strips; 25 m on roll; 6 mm wide; plain; Self-adhesive; white



**Item No.: 210-831**  
Marking strips; on reel; 2.3 mm wide; plain; Self-adhesive; white



**Item No.: 210-832**  
Marking strips; on reel; 3 mm wide; plain; Self-adhesive; white



**Item No.: 210-834**  
Marking strips; on reel; 5 mm wide; plain; Self-adhesive; white

### 1.2.5 Protective warning marker

#### 1.2.5.1 Cover



**Item No.: 280-415**  
Protective warning marker; for 5 terminal blocks; with high-voltage symbol, black; yellow

### 1.2.6 Strain relief

#### 1.2.6.1 Strain relief



**Item No.: 769-413**  
Strain relief plate; for female and male connectors; 1 part; Pin spacing 5 mm; 6- to 9-pole; gray

## 1.2.7 Tool

### 1.2.7.1 Operating tool



**Item No.: 210-490**

Operating tool

**Item No.: 769-434**

Operating tool; made of insulating material;  
1-way; loose; white

## Installation Notes

### Installation

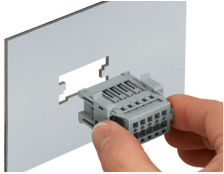

Insert a male connector with snap-in flanges (769-605/006-000) into the cutout.

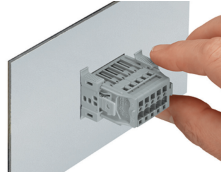

Secure the snap-in flange.

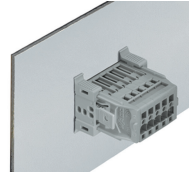

Male connector with snap-in flanges (769-605/006-000) in cutout

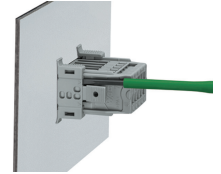

For removal, insert operating tool (2.5 mm blade) into release slot.

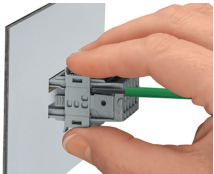

Press center part on both the top and bottom of the connector. Then remove snap-in flange.

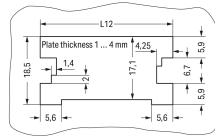

$L12 = \text{pole no.} \times \text{pin spacing} + 10.2 \text{ mm}$

Sheet metal cutout (for female connectors without locking levers)  
Male connectors with CAGE CLAMP® connection (769-6xx/006-000) and snap-in flanges

## Conductor termination



Operating tool

Inserting a conductor via operating tool (example shows a male connector).

## Marking



Labeling a male connector with CAGE CLAMP® connection via Mini-WSB Quick Markers.